

Active infrared presence sensor for swinging, revolving & folding automatic doors

1 Safety instructions

- * The device must only be operated at a protective low voltage with safe electrical insulation. Product repairs must be performed solely by the manufacturer.
- * Shut off all power going to the sensor before attempting any wiring procedures.
- * Maintain a clean & safe environment when working in public areas.
- * Constantly be aware of pedestrian traffic around the door area.
- * Always stop pedestrian traffic through the doorway when performing tests that may result in unexpected reactions by the door.
- * Always check placement of all wiring and components before powering up to ensure that moving door parts will not catch any wires and cause damage to equipment.
- * Ensure compliance with all applicable safety standards (i.e. ANSI A156.10) upon completion of installation.

DO NOT LEAVE ANY PROBLEMS UNRESOLVED - NEVER SACRIFICE SAFETY FOR ANY REASON

2 Preparation / Installation

2.1 Opening the housing

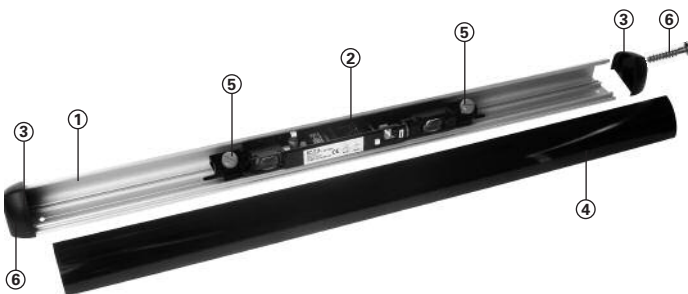

- ① Aluminum extrusion Remove end covers by removing screws.
- ② Sensor Remove front cover.
- ③ End cap 2 x
- ④ Front cover
- ⑤ Mounting brackets 2 x
- ⑥ Phillips head screws 2 x

2.2 Removing the sensor

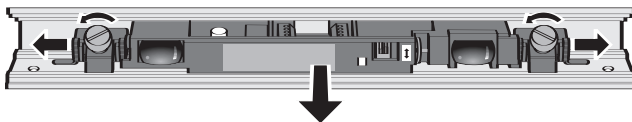

- Option 1
Release the red screws on both mounting brackets, then slide them to the side.
- Option 2
Release the red screws, then slide the bracket holders together with the sensor carefully out of the aluminium housing.

2.3 Mounting the housing

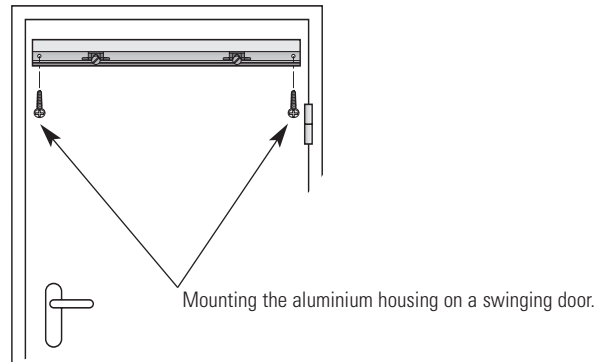

2.4 Selecting the detection area

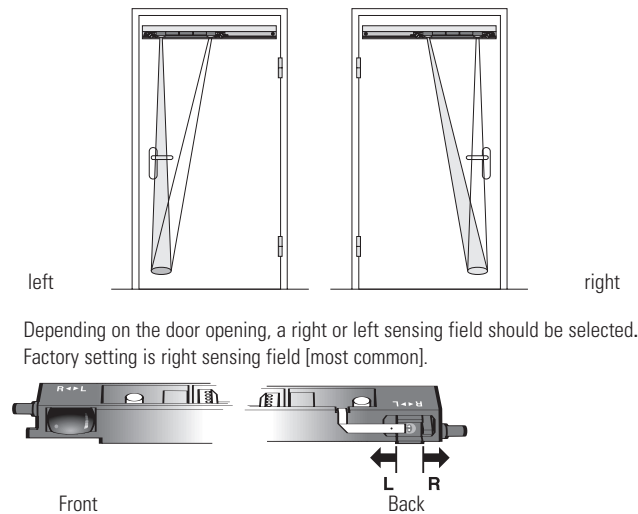

To change the sensing field type, slide the plastic block to position L or R. It can be found on the back of side the optics.

Position of the detection area
L = Left
R = Right

2.5 Selecting the switching and operating modes



Switch 1 Switch 2



Operating mode: moving or stationary

► Moving mode: Switch 1 up

- no background necessary, floor is ignored (background suppression)
- the sensor cannot be tested in this operating mode (test input TI without function)



► Stationary mode: Switch 1 down (not recommended if mounted on a moving door)

- a stable background is essential, the floor is analyzed (background evaluation)
- the sensor can be tested via the test input



Switching mode active/passive variable

► Passive variable: Switch 2 up

- on detection, the relay switches from common to nc (see section 2.6)
- this setting has the advantage that a power failure or wire damage is interpreted as a detection and will trigger the respective safety feature of the door



► Active switching: Switch 2 down

- on detection, the relay switches from common to no (see section 2.6)

2.6 Electrical connection

The terminal block can be pushed out from below with a screwdriver if necessary

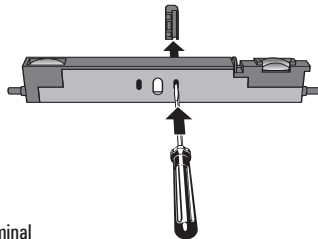

Connect the cables to the terminal based on the diagram below

standard

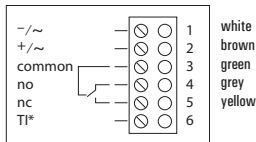

switch 2 down

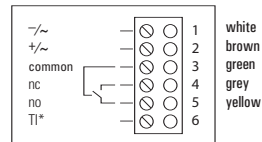

*Test input (only if switch 1 is down)

Note on test input:

- Testing is only possible for:
- stationary mode
 - DC supply Power

Function of test input:

When the test input is active (voltage present), the sensor is switched off. This simulates a detection and when functioning correctly causes the relay to switch.

Plug the plug-in screw terminal back in again and route the cable away over the guide bridge.

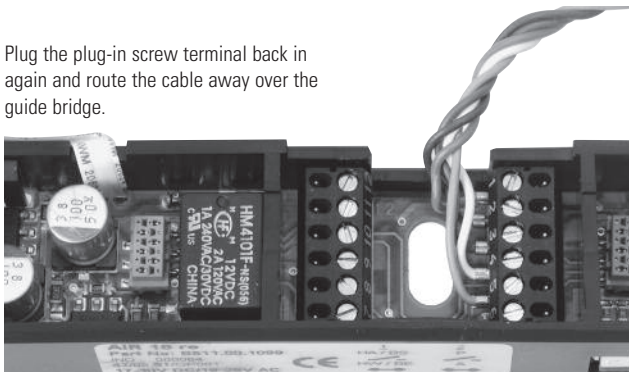

2.7 Mounting the sensor

Mount the sensor in the housing and slide both mounting brackets against the sensor.



Note:
Put cable **behind** the mounting bracket. Make sure the red screws on the mounting brackets are fully unscrewed before inserting the sensor into the brackets.

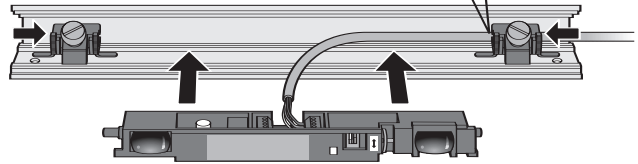
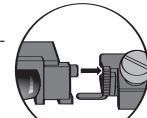

2.8 Checking the settings

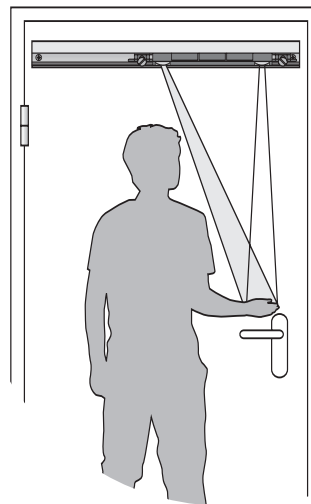

Power on the sensor after all installations have been completed

Check the detection range with a regular sheet of paper (white, letter size) or the palm of your hand.

If necessary, adjust the detection characteristics as described in sections 2.9, 2.10 and 2.11.

Note: The LED lights up when the sensor detects a presence.

2.9 Scanning range

Adjust the scanning range with the adjustment wheel.

Increasing the scanning range

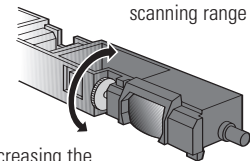

Decreasing the scanning range

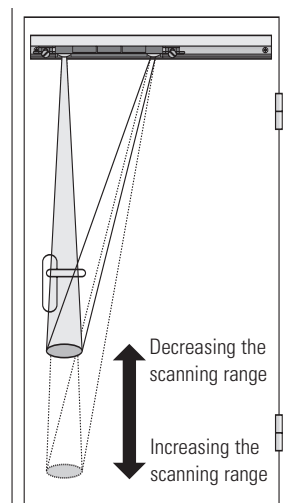

Set the scanning range to approx. 9.84" (25 cm) above the floor with a maximum of 28" to fulfill ANSI 156.10.

2.10 Adjust detection area

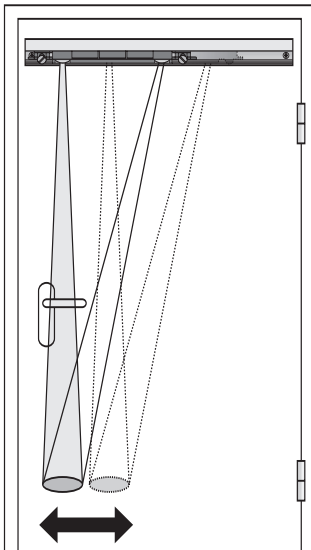

Adjust the detection area by sliding the sensor (red mounting brackets should be partly unscrewed for easy adjustments).

2.12 Secure the sensor position

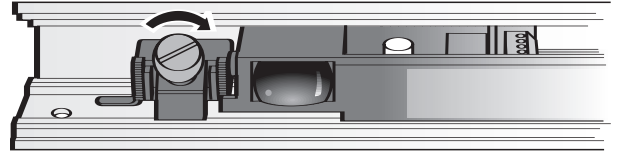

When all the settings are completed, secure the sensor by tightening the red screws on the mounting brackets.

2.11 Inclination angle

Set the inclination angle by carefully rotating the sensor up or down with 2 hands.

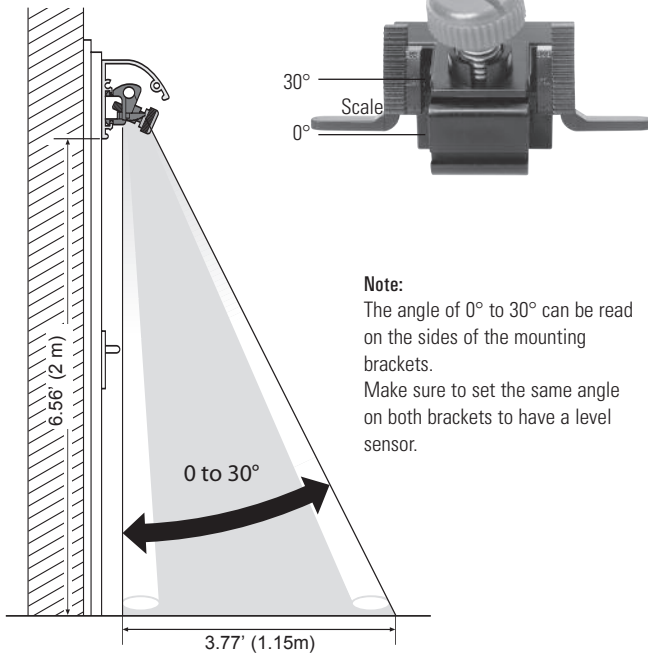

Note:
The angle of 0° to 30° can be read on the sides of the mounting brackets. Make sure to set the same angle on both brackets to have a level sensor.

2.13 Closing the housing

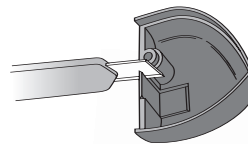

Note:
If necessary, cut out the cable exit indicated on the end cover.



Attach the front cover to the aluminium housing. Mount the end caps using the screws.

2.14 Adaptation for ANSI/BHMA compliance



To comply with the ANSI/BHMA requirement of 1" max between leading edge and sensing field, cut the side bracket on the leading edge side and slide the sensor/brackets assembly as far as possible towards the leading edge.

The Topscan has been independently tested by TÜV and certified compliant with ANSI standards.

side brackets

3 Extended applications

3.1 Multiple sensors in a single housing

Multiple sensors can be connected to one another using the cable (TS-Flat cable).



The operating voltage (terminals 1+2) and the relay output (terminals 3, 4 and 5) only need to be connected once to a single sensor.

3.2 External sensors

An external sensor is connected via the plug-in screw terminal 7–12.

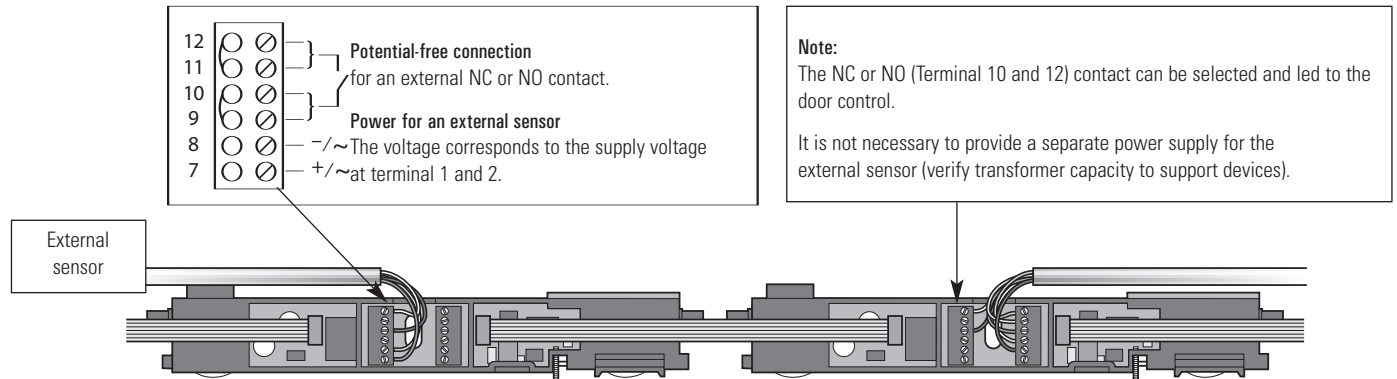

4 Troubleshooting

Problem	Possible causes	Corrective actions
Doors only open cyclically or partially	<ul style="list-style-type: none"> – In the moving application, the sensor is configured for stationary mode – Scanning range set too close to the ground 	<ul style="list-style-type: none"> – Change the operating mode to moving, see section 2.5 – Adjust scanning range, see section 2.9
Doors do not open LED does not light up	<ul style="list-style-type: none"> – Switching type (active/passive) set incorrectly – Scanning range set too close to the ground 	<ul style="list-style-type: none"> – Change switching type (active/passive), see section 2.5 – Adjust scanning range, see section 2.9
Doors do not open LED is permanently lit	<ul style="list-style-type: none"> – Switching type (active/passive) set incorrectly – Scanning range set too close to the ground 	<ul style="list-style-type: none"> – Change switching type (active/passive), see section 2.5 – Adjust scanning range, see section 2.9
Door opens LED is permanently lit	<ul style="list-style-type: none"> – Switching type (active/passive) set incorrectly – Scanning range set too close to the ground 	<ul style="list-style-type: none"> – Change switching type (active/passive), see section 2.5 – Adjust scanning range, see section 2.9
The sensor detects no objects	<ul style="list-style-type: none"> – Scanning range set too far from the ground – Flat-ribbon connections between two sensors are connected incorrectly – Heavy direct rain 	<ul style="list-style-type: none"> – Adjust scanning range, see section 2.9 – Replace sensors – Replace sensor
The sensor detects permanently	<ul style="list-style-type: none"> – Fluorescent lamp in the vicinity of the sensor 	<ul style="list-style-type: none"> – Change inclination angle, see section 2.11 – Change scanning range, see section 2.9 – Remove fluorescent lamp
Irregular detection without an object in the detection field	<ul style="list-style-type: none"> – Reflecting background and at the same time almost vertically set inclination angle 	<ul style="list-style-type: none"> – Increase inclination angle (see section 2.11) or remove reflecting background

5 Technical data

Detection area	3.94"–98.4" (100–2500 mm) 19.7"–98.4" (500–2500 mm)	For stationary mode For moving mode
Scanning range setting	Mech. adjustment wheel 59.1"–98.4" (1500–2500 mm)	Triangulation principle
Temperature dependence	+140 °F (+60 °C): +10% –4 °F (–20 °C): –10%	Deviation from 68° F (20°C) with reference to the scanning range set
Black/White difference	max. 20% White: Larger scanning range Black: Smaller scanning range	Difference between black and white with reference to the scanning range set
Detection area	Approx. 2.95" (75 mm) diameter	For a scanning range of 78.74" (2000 mm)
Type of light	IREC	Pulsed alternating light 880 nm
Operating voltage	17–30 V DC / 18–28 V AC	
Current consumption	< 110 mA	
Signal output	Relay, changeover contact Max. switching voltage 48V AC/DC Max. switching current 0.5A AC/DC Max. switching capacity 55VA/24W	Electrically isolated Nominal current (ohmic load) 1A/ 24V DC For ind./cap. load, provide spark quenching Ohmic load
Response time on detection	Approx. 30 ms	
Drop-out time after detection	Max. 150 ms Max. 2 s	For stationary mode For moving mode
Response time with test signal	Max. 500 ms	Only possible for DC operation
Test input	With +UB = 17–30V DC	Only for stationary mode
Operating mode	Moving / stationary	Can be switched over
Function indication	Red LED	Lights up when an object is detected
Connection type	Plug-in screw terminal	
Protection class	Suitable for use in acc. with IP52	
Housing material	Aluminum/ABS	
Front cover	PC (black)	
Distance between optical units	5.91" (150 mm)	Transmitter/receiver
Operating temperature	–4° F to +140° F (–20° C to +60° C)	
Storage temperature	–40° F to +176° F (–40° C to +80° C)	
Weight	1.59 oz. (45 g)	Without housing
Sensor dimensions	7.8" x 1.2" x 0.78" (198.5 x 31 x 20 mm)	Length / Width / Height without housing
Housing color	Silver, black or white	Depending on version
Electromagnetic compatibility	Interference immunity in acc. with: EN 61000-6-1, EN 61000-6-2 Emitted interference in acc. with: EN 61000-6-3, EN 61000-6-4	CE in acc. with EMC directive 89/336 EEC TUV independently tested and certified to comply with ANSI 156.10-2005

ADSF UK LTD

Tel: 08700 434512

Fax: 08700 434524